

**IMPORTANT!! PLEASE READ ENTIRE INSTRUCTION SHEET BEFORE ASSEMBLY!!  
TO EXPEDITE ANY FUTURE WARRANTY CLAIMS, PLEASE KEEP INSTRUCTION SHEET, WARRANTY CARD AND RECEIPT**

**Step 1:** Identify all parts packed in the carton against the parts list. Remove all protective materials. Place parts on a non-abrasive surface to avoid scratching. If you are missing any parts or unsure how to proceed with the assembly, call our Customer Service Center at 1-888-707-1880. **Do not attempt assembly if any parts are missing or damaged.**

**Step 2:** Place the swivel base (with rocker assembly) on a flat, solid surface. Make sure the rocker assembly is positioned all the way into the base. It may have shifted or vibrated out during shipment.

**Step 3: Important: We recommend 2 people work together to assemble the chair.** Note the arrow labels on the "U" bar and the rocker assembly. Also note the horseshoe shape of the rocker plate. Point the open end of the horseshoe away from you. The arrows on the rocker assembly should be pointing towards you. Set the chair frame on the rocker assembly with front of the seat facing you and the arrows on the "U" bar pointing towards you as shown in *Figure 1*. This is very important for a safe, balanced rocking motion. **If the chair frame has been properly positioned on the rocker assembly, all arrows on the "U" bar and rocker assembly will be pointing in the same direction.**

**Step 4: Critical Step: The "U" metal plates must be installed in the proper location.** Read this step and carefully examine. Insert the "U" metal plate so that the "U" bar and rocker plate are between both sides of the "U" metal plate. Make sure that the holes in the "U" metal plate are completely aligned with the holes in the "U" bar as shown in *Figure 2*. Guide the bolts through the holes on the bottom side of the "U" metal plate, through the holes in the "U" bar portion of the chair, through the holes in the rocker plate and then, most importantly, through the holes in the top side of the "U" metal plate. It is very important that the holes in the bottom of the "U" metal plate are placed directly beneath the holes in the rocker plate. Add a spring washer and a nut to each bolt as shown in *Figure 2*. **Hand tighten nuts 3-4 revolutions only.** Repeat the same procedure on the other side.

**CAUTION:** Failure to place the "U" metal plates under the rocker plates and above the "U" bar exactly as shown in the diagram will cause the bolt heads and nuts to damage the structure of the rocker plates and the "U" bar. Damage due to over tightening of bolts or improper assembly could cause injury and may void your warranty.

**Step 5:** Tighten all nuts and bolts with the hex wrenches provided. **Bolts must be FULLY tightened.** Remove the arrow labels from the "U" bar and rocker assembly. Cover bolts with bolt covers.

**Step 6:** Your chair should be ready for use. If your chair is not rocking properly, double-check your assembly procedure, especially Steps 3-4. If the chair rocks too far forward to or is difficult to rock backwards, you have probably installed the seat frame backwards on the rocker assembly. If you need further assistance, please call our Customer Service Center at 1-888-707-1880.

**IMPORTANT NOTE:** Damage to frames or rocker plates resulting from not FULLY tightening the bolts, is not covered under warranty. Please read all instructions carefully before assembly. If you have any questions regarding your assembly, call our Customer Service Center at 1-888-707-1880.

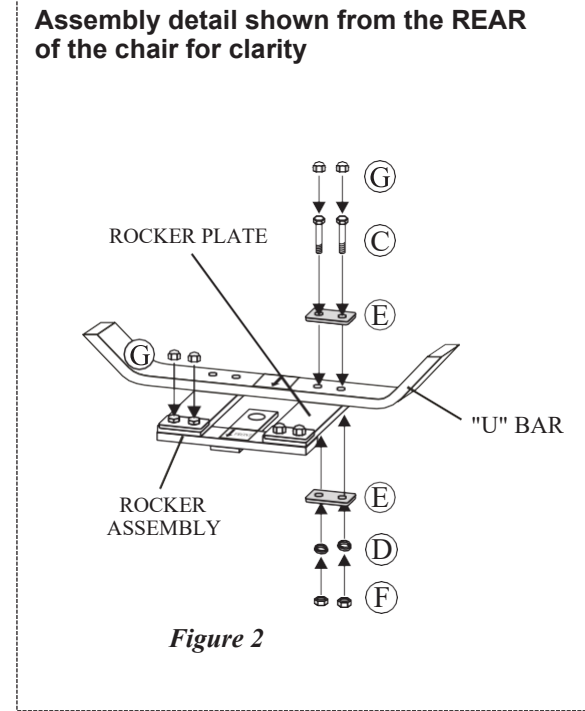
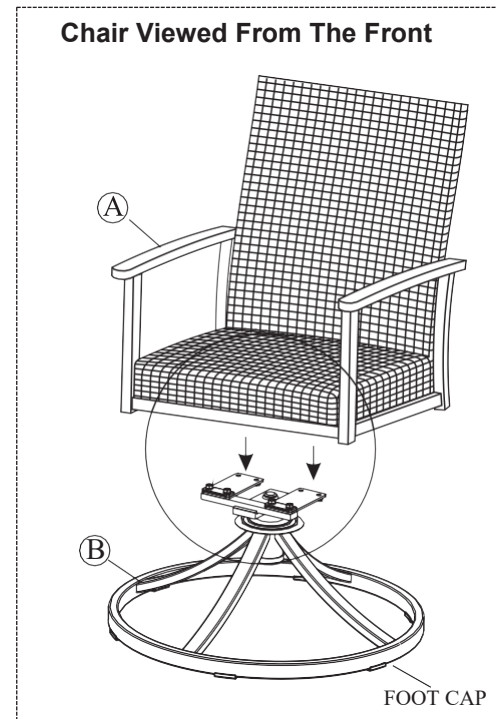

*Figure 2*

\* NOTE: PARTS SHOWN ON PARTS LIST ARE NOT TO SCALE

	PARTS LIST	DESCRIPTION	ORDER PART #	QTY	PARTS LIST	DESCRIPTION	ORDER PART #	QTY
A		CHAIR FRAME		1		HEX WRENCH-1	HW0008	1
B		SWIVEL BASE & ROCKER ASSEMBLY		1		HEX WRENCH-2	HW0007	1
C		5/16" X 46 MM BOLT	HW0791	4		ROCKER PLATE FACTORY ASSEMBLY	G0008	
D		Ø8.0 X 2.3 MM SPRING WASHER	HW0003	4		FOOT CAP FACTORY ASSEMBLY	FC0159	
E		METAL PLATE	HW0012	4				
F		5/16" NUT	HW0015	4				
G		BOLT COVER	HW0028	8				

**B1T00401**

## CARE AND MAINTENANCE

### FRAMES

*Cleaning* - Use mild soap and warm water. Do not use abrasive materials, cleaners, or bleach products. Rinse with clean water and dry thoroughly.

*Maintenance* - Periodically clean and dry thoroughly. Be sure to drain any water accumulated inside the frames. To thoroughly drain frames, remove foot caps and tilt the frames, if necessary, to remove all water. This is critical. Water allowed to accumulate inside the frames and then exposed to sub-freezing temperatures can cause damage to the frame tubing. Such damage is not covered under warranty. Always clean, drain, and dry thoroughly before storing for the winter. For best results, always store or cover your furniture when not in use. We recommend commercially available outdoor furniture covers. Any small nicks or scratches can be covered with a light application of touch-up paint.

\*\* When cleaning or moving large or heavy items, always have two people work together. Never drag furniture.

### FABRICS (CUSHIONS/SLINGS)

*Cleaning* - Wipe minor spills immediately. Clean with mild soap, warm clean water, and a soft cloth. Do not use abrasive materials, cleansers, or bleach products. Although fabric has been treated to resist stains, occasional use of commercially available fabric cleaners may be necessary. Follow manufacturer's instructions.

*Maintenance* - The best way to maintain the beauty of cushions and slings is to store them in a dry area and out of the elements when not in use or cover with commercially available outdoor furniture covers.

### STRAPS

*Cleaning* - Wash frequently with mild soap, warm water, and a soft cloth. Rinse thoroughly with warm, clean water. Do not use abrasive materials, cleansers, or bleach products.

*Maintenance* - Periodic application of commercially available vinyl cleaners and vinyl protectors will enhance the look and prolong the life of straps. If your strap chair has cushions, make sure any vinyl protectors applied are completely dry before placing cushion back on the chair.

### LIMITED WARRANTY

For full warranty details visit [www.agiocanada.ca/warranty](http://www.agiocanada.ca/warranty)

**Warranty limitations:** This warranty is subject to the limitations set forth above. In addition, this warranty is made to the original purchaser only, and is effective only when item(s) is purchased from one of our authorized dealers. This warranty is not transferable. For warranty replacements based on warranty claims submitted within the first year of purchase, we will pay shipping and handling charges within Canada. After the first year, shipping and handling charges are your responsibility. We will not be responsible for charges associated with shipments outside the of Canada at any time or for any reason.

**Warranty exclusions:** This warranty is subject to the exclusions as set forth above. In addition, the following are excluded from coverage under this warranty: any item used for commercial, contract or any other non-residential purpose; clearance items, display models or items purchased "as is"; freight damage; items subject to misuse, abuse, neglect or lack of proper care and maintenance (including without limitation as provided in any "care and maintenance guide"); normal wear and tear; damage caused by acts of nature, acts of force majeure, vandalism, fire or other casualty, or improper assembly; hardware against corrosion or rusting; purchased or replacement parts; and all plastic parts. Also excluded are loss of use or time; inconvenience; money; travel; packaging; or incidental, special or consequential damages of any kind. Replacement of defective items as provided herein shall constitute your sole and exclusive remedy for items which are not as warranted. In no event shall our responsibility exceed the purchase price of the items found to be other than as warranted. This warranty is the exclusive statement of your rights with respect to the defects in the items you have purchased and supersedes any other express warranty or statement, written or oral, made in connection with the purchase and sale of such items. When used herein, the term "item" when used in the singular, refers to the specific item found to be defective, and not to the entire set of which the item is a part.

**Some provinces do not allow exclusion or limitation of incidental or consequential damages, so that limitation above may not apply to you. This warranty gives you specific legal rights, and you may also have other rights which vary from province to province.**

Furniture covers are a great way to protect your set from harsh elements of weather and UV light. However, it is important to ensure furniture and covers are free of moisture and debris before covering. It is also necessary to promptly uncover furniture after rain and during periods of high humidity to prevent moisture build up. Failure to do so can lead to permanent surface and finish damage.



# Agio Nantucket Swivel Rocker ASSEMBLY INSTRUCTIONS

Model# 18616407330

## PATIO FURNITURE & ACCESSORIES ASSEMBLY INSTRUCTIONS IMPORTANT!!!

STOP! PLEASE READ THESE INSTRUCTIONS CAREFULLY BEFORE ASSEMBLY. MAKE SURE YOU HAVE ALL THE PARTS AND HARDWARE AS IDENTIFIED ON THE PARTS LIST.

***MISSING PARTS? DAMAGED PARTS? DON'T GO BACK TO THE RETAILER. WE CAN HELP YOU FASTER!***



**Questions, Problems, Missing Parts? Before returning to your retailer, call our bilingual customer service department in Canada at 1-888-707-1880, Monday-Friday, 8:30 a.m. – 5 p.m. Eastern Time or visit [www.agiocanada.ca](http://www.agiocanada.ca)**

TO EXPEDITE ANY FUTURE WARRANTY CLAIMS, RETAIN THE INSTRUCTION SHEET, WARRANTY CARD, AND RECEIPT FOR FUTURE USE. YOU ARE ENCOURAGED TO REGISTER YOUR PURCHASE ON OUR WEBSITE AT [www.agiocanada.ca](http://www.agiocanada.ca)

FOR ADDITIONAL ONLINE VIDEO SUPPORT ON ASSEMBLY, TROUBLESHOOTING, AND CARE AND MAINTENANCE OF YOUR AGIO OUTDOOR FURNITURE, PLEASE VISIT OUR WEBSITE AT: [www.agiocanada.ca](http://www.agiocanada.ca)