

**IMPORTANT!! PLEASE READ ENTIRE INSTRUCTION SHEET BEFORE ASSEMBLY!!
TO EXPEDITE ANY FUTURE WARRANTY CLAIMS, PLEASE KEEP INSTRUCTION SHEET, WARRANTY CARD AND RECEIPT**

Step 1: Carefully remove tile and set aside until Step 5. Lay tile flat--do not stand tile on edge. Remove all protective materials and set parts on a flat, non-abrasive surface. Identify parts packed in the carton against the parts list.

Step 2: Place the table rim upside down on a flat, non-abrasive surface. Attach a table leg to the table rim by using the 1/4 x 20mm bolt and washer as shown in **Figure 1**. Guide the bolt through the hole in the table leg into the pre-drilled hole in the table rim. **Hand tighten only 2-3 turns.** Repeat for the other three legs.

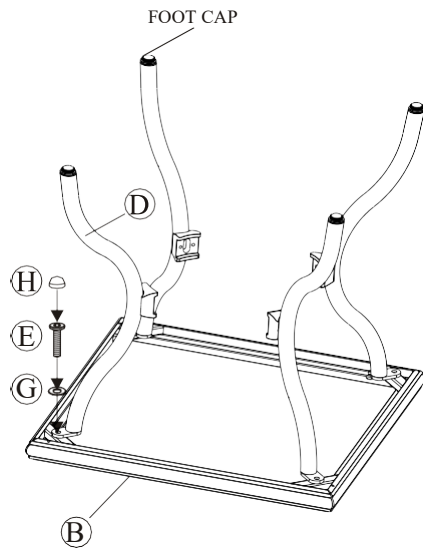

Figure 1

Step 3: Attach a leg to the leg connector bracket by using the bolts and washers as shown in **Figure 2**. Guide the bolts through the holes in the leg connector bracket, into the pre-drilled hole in the leg. **Hand tighten only 2-3 turns.** Repeat for the other three legs.

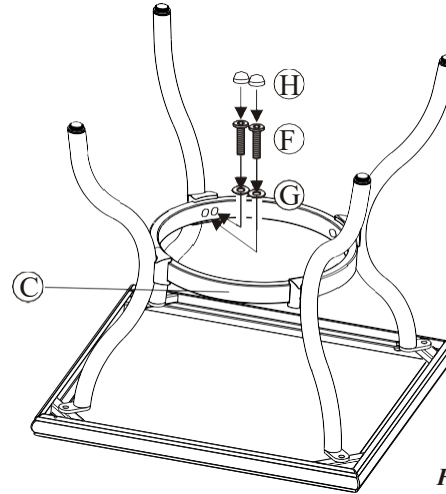



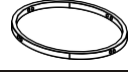







Figure 2

Step 4: After making any necessary adjustments to the alignment of the table base and table rim, use the hex bolt driver to tighten all bolts. **Note:** each bolt must be tightened a few revolutions at a time. In order to apply equal pressure to all bolt joints, we recommend working in a cross corner (X fashion). Repeat until all bolts are tight. **Do not over tighten.** Over tightening may strip bolts. Cover all bolts with covers.

Step 5: With the help of another person, turn the table in the upright position. Note the clear bumpers spaced evenly throughout the inside of the rim. Carefully place tile inside the rim, resting on the clear bumpers. Your table is now ready for use.

IMPORTANT NOTE: Damage to welds or frames resulting from over tightened bolts or improper assembly is not covered under our warranty. Please read all instructions carefully before assembly. If you have any questions regarding your assembly, call our Customer Service Center at 1-888-707-1880.

** NOTE: PARTS SHOWN ON PARTS LIST ARE NOT TO SCALE*

	<u>PARTS LIST</u>	<u>DESCRIPTION</u>	<u>ORDER PART #</u>	<u>QTY</u>
A		TILE	AT73157	1
B		TABLE RIM	AT73158	1
C		LEG CONNECTOR BRACKET	AT73159	1
D		TABLE LEG	AT73160	4
E		1/4" X 20 MM BOLT	HW0036	4
F		1/4" X 30 MM BOLT	HW0038	8
G		Ø6.5 X 1.0 MM WASHER	HW0004	12
H		BOLT COVER	HW0105	12
I		HEX BOLT DRIVER	HW0006	1
		TABLE BUMPER FACTORY ASSEMBLY	G0217	
		FOOT CAP FACTORY ASSEMBLY	FC0614	

APE04817

CARE AND MAINTENANCE

FRAMES

Cleaning - Use mild soap and warm water. Do not use abrasive materials, cleansers or bleach products. Rinse with clean water and dry thoroughly.

Maintenance - Periodically clean and dry thoroughly. Be sure to drain any water accumulated inside the frames. To thoroughly drain frames, remove foot caps and tilt the frames, if necessary, to remove all water. This is critical. Water allowed to accumulate inside the frames and then exposed to sub-freezing temperatures can cause damage to the frame tubing. Such damage is not covered under warranty. Always clean, drain and dry thoroughly before storing for the winter. For best results, always store or cover your furniture when not in use. We recommend commercially available outdoor furniture covers. Any small nicks or scratches can be covered with a light application of touch-up paint.

** When cleaning or moving large or heavy items, always have two people work together. Never drag furniture.

CERAMIC TILE

Use clean water and mild detergent or commercially available ceramic tile cleaners as necessary. Do not use abrasive materials or cleansers as they may scratch the surface of the tiles. Dry with a soft cloth. Do not use commercially available ceramic tile cleaners on table frame.

SPECIAL WARNINGS!!!

PLEASE TAKE PRECAUTION AND DO NOT ALLOW ANYONE TO CLIMB, STAND, CRAWL OR WALK ON TOP OF THE TABLE.

UMBRELLA USAGE WARNING!

If you will be using an umbrella with your table, make sure the plastic umbrella ring is inserted into the hole in the center of the table. Place the umbrella through the opening and into an umbrella stand made of cast iron, wrought iron, steel plate or blow molded plastic filled with 20-50 lbs or 9-22 kgs of sand or water. If your table is 72" or 182 cm or larger, we recommend a weight of at least 50 lbs or 22 kgs or more. NEVER USE AN UMBRELLA WITH A TABLE WITHOUT USING AN UMBRELLA BASE OR RING AS DESCRIBED ABOVE. ALWAYS REMOVE YOUR UMBRELLA FROM THE TABLE WHEN NOT IN USE. NEVER USE AN UMBRELLA DURING STORMS OR WINDY CONDITIONS.

LIMITED WARRANTY

For full warranty details visit www.agiocanada.ca/warranty

Warranty limitations: This warranty is subject to the limitations set forth above. In addition, this warranty is made to the original purchaser only, and is effective only when item(s) is purchased from one of our authorized dealers. This warranty is not transferable. For warranty replacements based on warranty claims submitted within the first year of purchase, we will pay shipping and handling charges within Canada. After the first year, shipping and handling charges are your responsibility. We will not be responsible for charges associated with shipments outside the of Canada at any time or for any reason.

Warranty exclusions: This warranty is subject to the exclusions as set forth above. In addition, the following are excluded from coverage under this warranty: any item used for commercial, contract or any other non-residential purpose; clearance items, display models or items purchased "as is"; freight damage; items subject to misuse, abuse, neglect or lack of proper care and maintenance (including without limitation as provided in any "care and maintenance guide"); normal wear and tear; damage caused by acts of nature, acts of force majeure, vandalism, fire or other casualty, or improper assembly; hardware against corrosion or rusting; purchased or replacement parts; and all plastic parts. Also excluded are loss of use or time; inconvenience; money; travel; packaging; or incidental, special or consequential damages of any kind. Replacement of defective items as provided herein shall constitute your sole and exclusive remedy for items which are not as warranted. In no event shall our responsibility exceed the purchase price of the items found to be other than as warranted. This warranty is the exclusive statement of your rights with respect to the defects in the items you have purchased and supersedes any other express warranty or statement, written or oral, made in connection with the purchase and sale of such items. When used herein, the term "item" when used in the singular, refers to the specific item found to be defective, and not to the entire set of which the item is a part.

Some provinces do not allow exclusion or limitation of incidental or consequential damages, so that limitation above may not apply to you. This warranty gives you specific legal rights, and you may also have other rights which vary from province to province.

Furniture covers are a great way to protect your set from harsh elements of weather and UV light. However, it is important to ensure furniture and covers are free of moisture and debris before covering. It is also necessary to promptly uncover furniture after rain and during periods of high humidity to prevent moisture build up. Failure to do so can lead to permanent surface and finish damage.



Agiio Brookfield Table ASSEMBLY INSTRUCTIONS

Model# 18616403010

PATIO FURNITURE & ACCESSORIES ASSEMBLY INSTRUCTIONS

IMPORTANT!!!

STOP! PLEASE READ THESE INSTRUCTIONS CAREFULLY BEFORE ASSEMBLY. MAKE SURE YOU HAVE ALL THE PARTS AND HARDWARE AS IDENTIFIED ON THE PARTS LIST.

MISSING PARTS? DAMAGED PARTS? DON'T GO BACK TO THE RETAILER. WE CAN HELP YOU FASTER!



Questions, Problems, Missing Parts? Before returning to your retailer, call our bilingual customer service department in Canada at 1-888-707-1880, Monday-Friday, 8:30 a.m. – 5 p.m. Eastern Time or visit www.agiocanada.ca

TO EXPEDITE ANY FUTURE WARRANTY CLAIMS, RETAIN THE INSTRUCTION SHEET, WARRANTY CARD, AND RECEIPT FOR FUTURE USE. YOU ARE ENCOURAGED TO REGISTER YOUR PURCHASE ON OUR WEBSITE AT www.agiocanada.ca

FOR ADDITIONAL ONLINE VIDEO SUPPORT ON ASSEMBLY, TROUBLESHOOTING, AND CARE AND MAINTENANCE OF YOUR AGIO OUTDOOR FURNITURE, PLEASE VISIT OUR WEBSITE AT: www.agiocanada.ca